

# Fibre Channel



## FCA2540HS-CCXMC-FF-G Data Sheet Dual Channel Conduction Cooled Fibre Channel XMC

### FCA2540HS Conduction Cooled XMC

The FCA2540HS conduction cooled XMC is the 7<sup>th</sup> generation of Fibre Channel interfaces from Critical I/O. Critical I/O's Fibre Channel interfaces allow system designers to easily integrate Fibre Channel into storage and networking I/O (processor to processor) applications. Critical I/O Fibre Channel products employ a Silicon Stack architecture which completely offloads all protocol processing into dedicated silicon, unlike FPGA-based Fibre Channel products which push the upper layer protocol processing (e.g. FC-SCSI) back onto the host ("software stack"). With industry-leading software capability, a Silicon Stack architecture, and support for industry standard protocols such as SCSI and RDMA, Critical I/O Fibre Channel solutions enable high sustained throughput, ultra-low host processor overhead and very low latency.

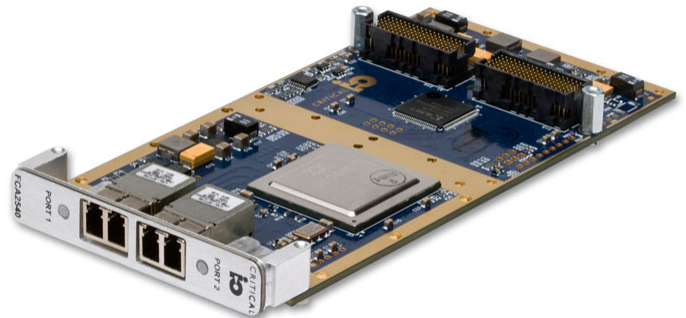

### FCA2540HS-CCXMC-FF-G Features:

- 8 Gbps dual channel (no support for 4/2/1 FC rates)
- ccXMC with 8-lane PCI-Express host interface
- 1600 MBytes/sec (full-duplex) max rate per channel
- 10 usec latency
- Hardware BIT (Built in Test)
- Low power consumption
- 2 front panel optical rugged "RJ size" LC connectors
- Comprehensive software library & driver support
- Rugged conduction cooled rear I/O XMC available
- RoHS LEAD FREE

### Network Features:

- FC-RDMA protocol support
- FC-FCLP support (messaging)
- FC-ASM support
- FC-AV support
- FC-IP support

### Storage Features:

- SCSI protocol support
- Initiator & target support

### Extensive Software Support & Capability

Critical I/O supplies the hardware, drivers, libraries, and protocol support you'll need for rapid system development without wasting time debugging drivers. The FCA2540HS hardware is accompanied by an extensive offering of software library and driver software products with support for real-time OS platforms (as well as mainstream OS platforms) running on a variety of embedded processors (PowerPC, DSP, Intel, etc.).

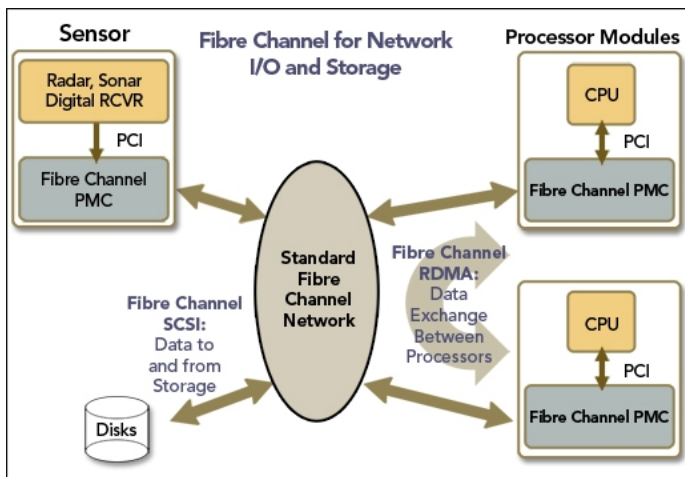

*Fibre Channel for Storage & Networking Applications*

### High Performance / Low Host Overhead

Transfer 1600 MBytes per second of data over a Fibre Channel network with minimal host CPU loading and ultra-low latency with the FCA2540HS Fibre Channel conduction cooled XMC. The FCA2540HS offers two independent channels of 8 Gbps Fibre Channel in a conduction cooled XMC with 8-lane PCI-Express. Each channel is capable of 1600 MBytes/sec and an overall sustained transfer rate of 3000 MBytes/sec. The Critical I/O Fibre Channel product family also provides simultaneous support for a multitude of protocols (both networking & storage) and Class 1, 2 & 3 FC Service.

## FCA2540HS Conduction Cooled XMC (optical) Technical Specifications

Controller Architecture	Highly integrated, low power, single chip dual channel Fibre Channel controller
Fibre Channel Rates	8 Gbps/channel (note: 4/2/1 Gb rates not supported)
Data Transfer Rate	1600 MBytes/sec (per channel, full-duplex) 3000 MBytes/sec sustained data rate (aggregate for interface)
Fibre Channel Topology	FC-AL, FC-AL2, point to point, switched fabric (FL_Port and F_Port)
Class of Service	Class 1, 2 and 3 Fibre Channel Service
Protocol Support	SCSI-FCP, FC-AE-RDMA; FC-AE-FCLP; FC-AE-ASM; FC-AE-AV; FC-IP
Host Bus Interface	PCI-Express 2.0 (8 lanes 2.5Gb/s; 4 lanes 5Gb/s capable)
Ports	Two optical front panel ports
Connectors	Two optical rugged "RJ size" LC connectors
Form Factor	XMC, VITA 42.0, VITA 42.3, ANSI / VITA 20-2001 (R2005) (VITA 61 XMC2 configuration avail)
Power Requirements	+12VDC at 1.0A (max) or +5VDC at 2.2A (max) <b>standard configurations</b> (special factory configuration : +3.3VDC at 3.3A)
Power Consumption	5.5 Watts (typical) with 4-lane PCIe; 6.5 Watts (typical) with 8-lane PCIe
Temperature	Operating "R2 level": -40C to +85C; Storage: -55C to +105C
Vibration – Random	VITA 47 Class V3: 5Hz to 100Hz (PSD increasing at 3 dB per octave); 100Hz to 1000Hz (0.1g <sup>2</sup> /Hz); 1000Hz to 2000Hz (PSD decreasing at 6 dB per octave)
Shock	VITA 47 Class OS2: 40g peak sawtooth (11ms duration)
Humidity	Operating: 0-95%, non-condensing; Storage: 0-100%, non-condensing
Supported Host Processors	Intel, PowerPC, DSP, etc.
Software Support	OS Drivers: VxWorks & Linux; (limited support for Integrity, contact Critical I/O)
Model Number	FCA2540HS-CCXMC-FF-G-R2 (VITA 42); FCA2540HS-CCXMC6-FF-G-R2 (VITA 61)
Model Description	Fibre Channel conduction cooled XMC, 8 Gbit/sec, dual channel, front panel optical "RJ size" LC connectors, parylene C conformal coated, R2 rugged = -40C to +85C, RoHS LEAD FREE, no front panel bezel or LEDs on standard configuration (non-standard configurations available)

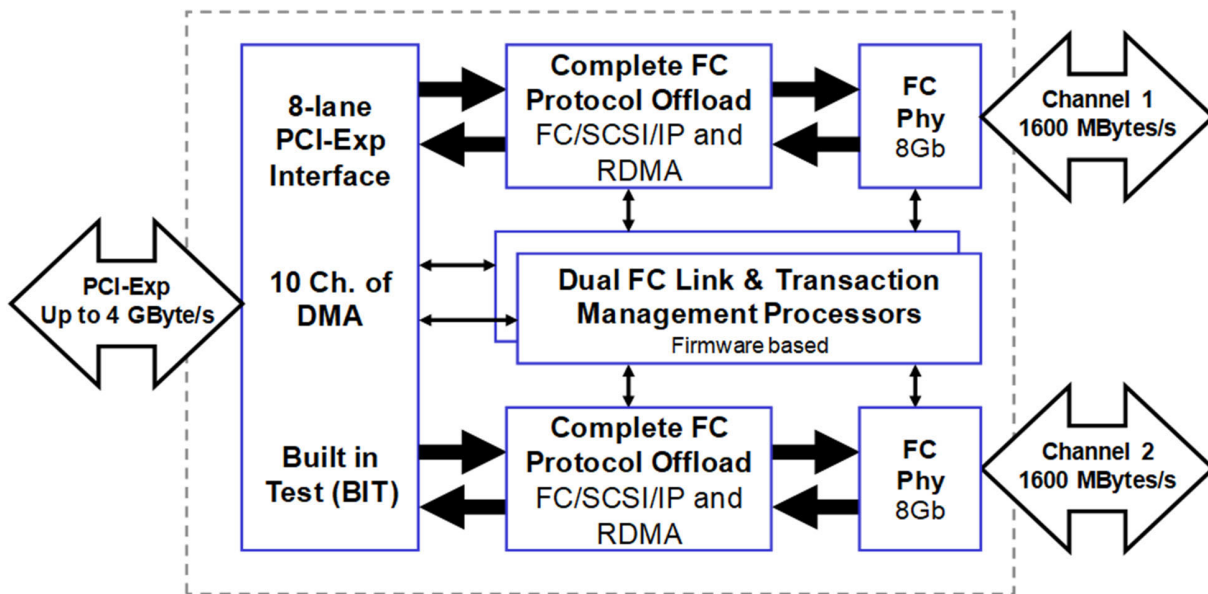

**Block Diagram:** The FCA2540HS CCXMC (front optical) provides two independent 8Gb Fibre Channel ports in a conduction cooled XMC form factor with 8 lane PCI-Express. Each channel employs a full silicon stack offload of the complete protocol stack delivering 1600 MBytes/sec on each channel and 3000 MBytes/sec overall sustained throughput with minimal host overhead and ultra-low latency.