

StoreEngine™ 3U OpenVPX Conduction Cooled



SE300-CCVPX Data Sheet: VPX Solid State Storage Blade – Recorder/File Server/Embedded RAID

StoreEngine™ VPX

StoreEngine is a scalable storage server designed for high performance embedded systems. The StoreEngine™ single slot blade can simultaneously serve block data (like a disk drive or RAID system), serve file data (like a NFS/CIFS file server), as well as providing high speed recording capabilities.

StoreEngine provides ultra high performance and high capacity all within a small size, weight, and power (SWaP) footprint. StoreEngine is ideal for high bandwidth data recording, file serving, and general purpose RAID applications.

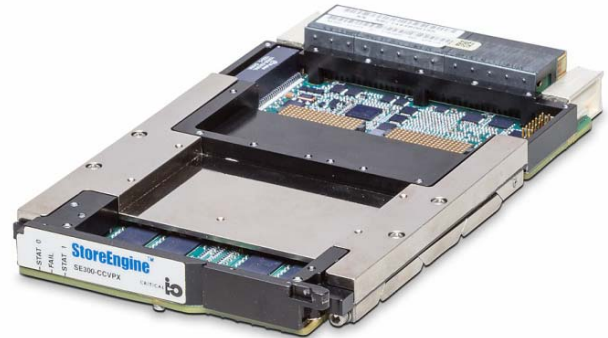

Embedded RAID

StoreEngine's embedded RAID provides block-level access to its onboard storage via PCIe or Fibre Channel interfaces. This is ideal for bandwidth driven applications such as the real-time acquisition of wide-band sensor, radar and video data streams. Access to storage is provided via standard VPX backplane PCIe fabric, as well as support for optional interfaces such as Fibre Channel, iSCSI, or FCoE. StoreEngine's embedded RAID can support up to 800 MBytes/s of sustained performance for a single blade and can be scaled by adding additional StoreEngines.

Scalable Data Recorder

StoreEngine can be used as a turn-key data recorder that provides a flexible and scalable recording platform to record high bandwidth data streams from ADCs, FPGAs, video streams, and other sources. By aggregating up to four StoreEngines, the recorder can support real time recording at rates of up to 2 GB/s with a capacity of up to 4 TB (Terabyte). Even higher rates and capacities are available by adding StorePak blades.

Network File Server

StoreEngine's NAS (Network Attached Storage) provides file-level access to its onboard RAID volume to a networked environment. This allows data storage to be accessed and shared via standard file access protocols such as NFS and CIFS, with other devices that are connected via a standard Ethernet network. StoreEngine supports NAS data access rates of up to 200 MBytes/s. NAS is ideal for systems and applications that require file-level and shared access to data among multiple clients but at more moderate access rates.

High Density

StoreEngine provides two PCIe SSDs in a single slot with optional expansion capability. Depending on the type of drive configuration selected, storage capacity for a single StoreEngine can be up to 1 Terabyte with additional capacity available by aggregating additional StoreEngine or StorePak blades.

SE300-CCVPX Features:

- High Capacity – up to 1 Terabyte per blade
- Low Power: 40 Watts typical
- High Performance: up to 800 MBytes/s per blade
- RAID 0/1/5
- Scalable High Speed Recording
- Network File Server (NFS/CIFS) functionality
- Concurrent Embedded RAID & NAS operation
- Built-in PCIe and Gigabit Ethernet I/O
- Optional RTM I/O: 10GbE & Fibre Channel
- Scalable & Expandable (add StoreEngines/StorePaks)
- Solid State Drives (optional expansion module)
- Rugged Conduction Cooled
- Air cooled available

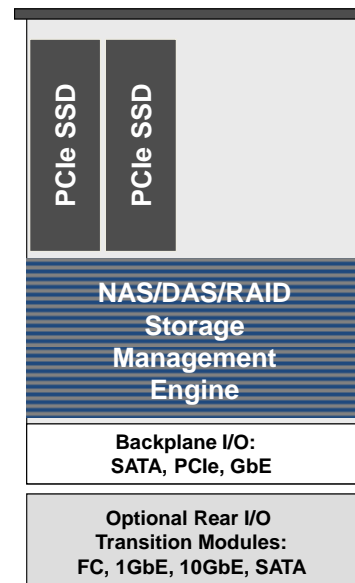

Critical I/O's StoreEngine provides secure, ultra reliable, high performance and high capacity storage.

Flexible Storage Interfaces

StoreEngine VPX supports a wide variety of standard and optional I/O. Backplane I/O expansion is available through several backplane rear-transition modules (RTMs).

- Backplane I/O – P1, P2
 - 2x 1Gb Ethernet P1 (supports NAS and iSCSI DAS)
 - 2x PCIe x4 P1 (supports PCIe DAS, recording)
 - 3x PCIe x4 P2 (with expansion module)
- Optional Rear Transition Module I/O
 - PCIe x8
 - 2x 8Gb Fibre Channel (support FC DAS)
 - 2x 1/10Gb Ethernet (supports NAS, SCSI/FCoE DAS)
 - Serial Port

StoreEngine Usage Models

StoreEngine supports a flexible set of usage models. In general, storage usage models are typically divided into two categories: Direct Attached Storage (DAS), which provides **block level** storage access (including RAID), and Network Attached Storage (NAS), which provides **file level** shared storage access.

For *DAS usage*, the client processor hosts a file system that is provided by the client's operating system. The client utilizes StoreEngine storage in a low level block mode. The allocation and use of these low level SATA storage blocks is controlled completely by the client file system, thus DAS stored data cannot typically be shared between clients. Data transfer rates for DAS storage are typically very high, over 700 MB/s.

For *NAS usage*, StoreEngine hosts its own file system, and thus it fully controls the low level allocation and use of SATA storage blocks. Client access to storage is provided via network file access protocols such as NFS and CIFS. Because storage access is file based, NAS stored data can be shared among multiple clients. Data transfer rates for NAS storage are more moderate (typically less than 100 MB/s).

High Performance Data Recording

Critical I/O's Data Recorder software is hosted on StoreEngines to provide an ultra high speed scalable recording system. The recorder software implements a recording file system that stripes data across multiple StoreEngines at rates of up to 2 GB/s, or to multiple StorePaks at rates of over 8 GB/s. It also provides unified playback of recorded data, allowing multiple StoreEngines and StorePaks to appear as a single data source when data is replayed.

The recording data source may be a stream from a PCIe connected ADC (or any other DMA capable PCIe data source such as an FPGA, or a processor board with PCIe), or a raw Ethernet or UDP/IP data stream. The PCIe data source may "push" data blocks to the StoreEngines at up to 800 MB/s per StoreEngine, or StorePaks may "pull" data from sources at up to 2 GB/s per StorePak. Many other recording architectures and modes are also supported; contact Critical I/O for more details.

High Speed Recording

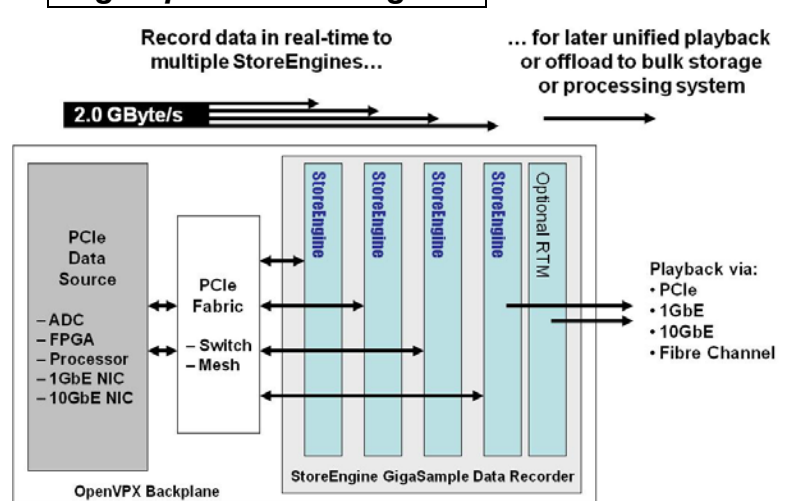

For data recording, the StoreEngine recorder blades, along with the data source, are typically hosted in a VPX rack, and are interconnected using a VPX mesh or VPX switched backplane.

PCIe DAS

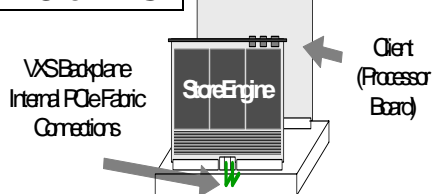

PCIe Direct Attach Storage is an efficient method of adding high performance RAID storage to an PCIe enabled embedded VPX processor board. PCIe connectivity from the client (processor board) to the StoreEngine is typically provided via backplane PCIe fabric. A lightweight StoreEngine driver runs on the client board, supporting sustained data transfer rates to and from StoreEngine of up to 700 MByte/s. StoreEngine client drivers are available for both VxWorks and Linux.

FC, iSCSI, FCoE DAS

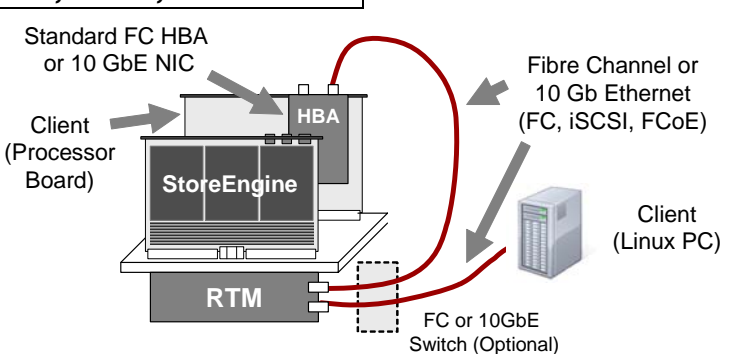

StoreEngine supports a wide variety of DAS interface options (in addition to the PCIe connected DAS described earlier). Fibre Channel is supported via optional Fibre Channel RTM, and iSCSI, and FCoE interface options are supported using the optional 10Gb Ethernet rear-transition module.

1 or 10 Gb Ethernet NAS

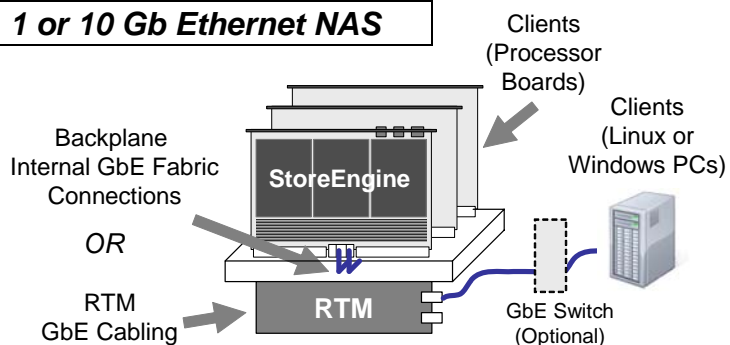

NAS clients are connected to StoreEngine via an 1 or 10 Gb Ethernet network. 1 Gb Ethernet connections are via backplane or RTM Ethernet connections. 10 GbE connections are made using the optional 10 GbE rear transition module. NAS clients leverage standard network file access protocols such as NFS and CIFS to access StoreEngine storage, which provides file level data sharing among all connected clients. The ultra high performance streaming NAS protocol also runs over 1 or 10 Gb Ethernet.

SATA Drive Options

StoreEngine supports the use of several different types of SATA drives, depending on specific application requirements. While standard StoreEngine configurations utilize Solid State Drives (SSDs), configurations using traditional rotating drives are also available on a special order basis.

- **SSD-SLC** – Single Level Cell SSDs provide the ultimate in storage reliability and performance. SLC SSDs provide very high write endurance and consistent performance, but have much smaller capacity than MLC SSDs
- **SSD-MLC** – Multi-Level Cell SSDs provide the reliability of flash based storage, with higher capacity, but lower performance as compared to SLC SSDs. MLC SSDs provide a good balance between reliability, capacity, cost, and performance.

RAID Options

In any of the DAS or NAS modes of operation, StoreEngine storage can be configured to operate as either RAID 0 or RAID 1. Both RAID 0 and RAID 1 modes aggregate the storage of all of the StoreEngine drives into a single “logical drive”. But they differ in levels of performance and data protection. RAID 1 mirrors data across SSDs for redundancy. When used with a StorePak blade, RAID 0, 1, and 5 are supported

Storage Expansion with StorePak

StoreEngine may be used in conjunction with StorePak VPX modules for increased storage capacity and performance. Each 3U StorePak module provides up to 6TB of easily hot-swappable storage. A PCIe connection is required between StoreEngine and StorePak(s).

Unified Web Based Management

StoreEngine provides a comprehensive web based management interface. This allows monitoring of status information, and configuration of interfaces, operating modes, and storage options. Some specific capabilities include:

- BIT status (self test, voltages, currents, temperatures)
- Storage and protocol configuration
- Recorder configuration and control
- Storage status (available/used capacity, status, errors)
- Network statistics
- Interface Status (link status, errors)
- Performance monitor
- Enable/Disable protocols & features
- Security and permissions
- Secure Erase

Built-In Test (BIT)

StoreEngine’s standard Power-On Self Test (POST) performs a test of the processor, cache, SDRAM memory, interfaces, and data paths. StoreEngine also runs a continuous basic BIT routine (CBIT), monitoring board/drive health. On-board temperatures, and power supply voltages and currents are also continuously monitored.

On-Line Performance Monitor

The condition of the on-board drives, including errors and performance levels is also continuously monitored, allowing users to be notified in the event that drive performance begins to degrade.

Data Security

StoreEngine has an embedded storage security engine that allows all data written to the on-board SATA drives to be optionally encrypted for enhanced data security. A secure-erase feature allows fast user-initiated purge of data.

Applications

The flexibility of StoreEngine allows it to be used for a large variety of embedded storage applications. StoreEngine replaces large power hungry external RAID or NAS boxes with a compact, simple, high performance, and high reliability single card solution.

- Linux/Unix/Solaris Network File Sharing using NFS/FTP
- Windows Network File Sharing using NFS or CIFS/SMB
- Data logging and system
- Intelligence, Surveillance, and Reconnaissance (ISR)
- Signal Intelligence data recording/ playback (SIGINT)
- Communications Intelligence data recording (COMINT)
- RADAR/SONAR data recording
- Imaging systems data recording
- In-system data capture with remote data playback
- Secure, encrypted data storage, with fast secure erase

StoreEngine Media Choices, Capacities and Performance Data by Model Number (with optional expansion module)

The types of storage media available for standard StoreEngine configurations are:

- **SSD Single Level Cell (SLC) Flash Media** – Characterized by highest reliability, high write endurance, excellent sequential and random read/write performance, but generally lower storage capacity. Good for all applications where performance and reliability are critical and capacity is secondary.
- **SSD Multi-Level Cell (MLC) Flash Media** -- Characterized by slightly lower reliability, lower write endurance, excellent sequential read/write performance, moderate random read/write performance, and high storage capacity. Good for sequential (streaming) read/write applications where performance and capacity are both important.

Media Characteristics & Storage Capacity of Standard StoreEngine Configurations

StoreEngine Model#:	Media Type	Raw* Capacity	Sequential Performance	Random Performance	Write Endurance	Reliability
SE300-CCVPX-ND	-	-	-	-	-	-
SE300-CCVPX-SP200	SSD-SLC	200 GB	Excellent	Excellent	Excellent	Very High
SE300-CCVPX-MC1024	SSD-MLC	1024 GB	Excellent	Moderate	Good	High

* usable capacity is less than raw capacity

Preliminary Performance Characteristics (with optional expansion module)

Recording Mode Performance of Standard Configurations (See Note 1 below)

StoreEngine Model#:	Sequential Read (1 MB block)	Sequential Write (1 MB block)
SE300-CCVPX-SP200	800 MByte/s	600 MByte/s
SE300-CCVPX-MC1024	800 MByte/s	800 MByte/s

DAS (direct block access) Performance of Standard Configurations (See Note 1 below)

StoreEngine Model#:	Sequential Read (RAID0, 1 MB block)	Sequential Write (RAID0, 1 MB block)
SE300-CCVPX-SP200	700 MByte/s	600 MByte/s
SE300-CCVPX-MC1024	700 MByte/s	800 MByte/s

NAS (NFS) Performance of Standard Configurations (See Note 1 below)

StoreEngine Model#	Sequential Read (RAID0, 1 MB block)	Sequential Write (RAID0, 1 MB block)
SE300-CCVPX-SP200	200 MByte/s	100 MByte/s
SE300-CCVPX-MC1024	200 MByte/s	100 MByte/s

Notes:

(1) Performance numbers shown are maximums using newly erased SSDs. Actual performance can vary greatly, and depends on the specifics of the application. Contact Critical I/O to discuss performance expectations.

Preliminary Technical Specifications

Controller Architecture	Storage Controller with optional Storage Expansion Module
Backplane Interfaces	2x PCIe x4 (4x PCIe x4 with optional expansion module) 2x 1000Base-T GbE (1000Base-X build option)
Optional Interfaces	2x 10Gb Ethernet 2x 1/2/4/8 Gb Fibre Channel
Performance	Recorder mode: up to 1 GB/s (higher with optional StorePaks) Direct Attached Storage (DAS) mode: up to 1 GB/s (higher with optional StorePaks) File Server (NAS) mode: up to 200 MB/s
DAS Protocol Support	PCIe DAS, Fibre Channel (iSCSI, FCoE support planned)
NAS Protocol Support	NFS, FTP, CIFS/SMB, USFTP
Security	Optional AES-256 encryption
Management	Web GUI, Network Management Protocol
Form Factor	3U VPX (1.0" pitch VITA 48) conduction cooled
Power Requirements	+5VDC at 8A +3.3VDC at 1.5A
Power Consumption	40 Watts (typical)
Temperature	Operating: -40C to +71C; Storage: -40C to +105C (contact Critical I/O for extended temperature range versions)
Humidity	0-95% non condensing
Vibration (random)	0.1g2/Hz (100-1000 Hz)
Shock	40g Peak sawtooth (11ms duration)
Supported Host Processors	Intel, PowerPC
Software Support	Linux, VxWorks, Windows
Model Number	SE300-CCVPX
Model Description	3U VPX StoreEngine, embedded storage controller with optional 2 PCIe Solid State drives, conduction cooled 3U VPX, extended temp (-40C to +71C), RoHS LEAD FREE

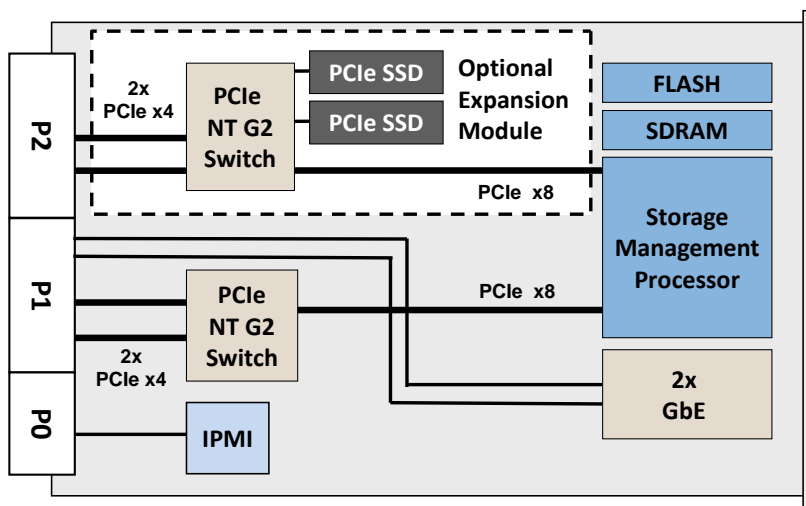

StoreEngine SE300-CCVPX Diagram.